

Assembly Instructions

BIFOLD FUTON FRAME LOUNGER

Instructions apply to all sizes:

• Twin • Love seat

N&D-1001

1A Assembled View.

Your arm style may vary

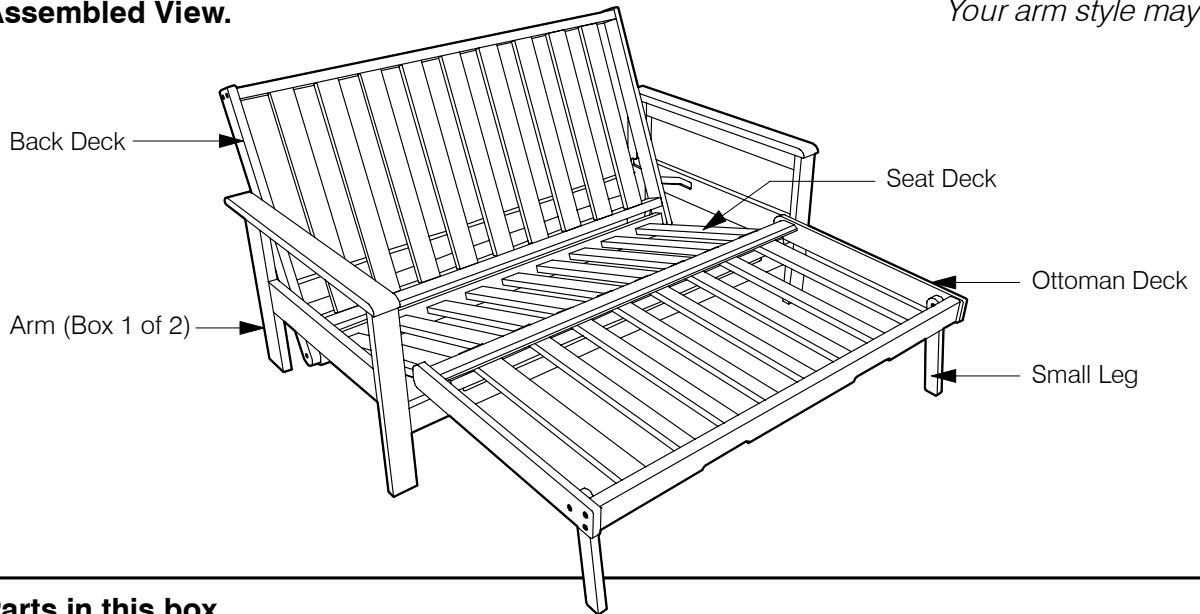

1B Parts in this box.

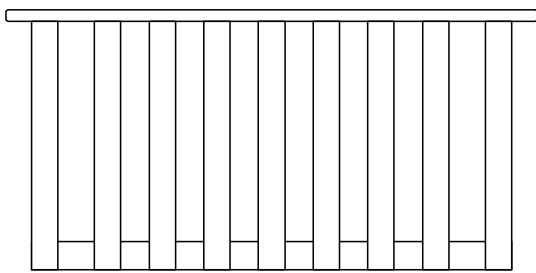

Seat Deck

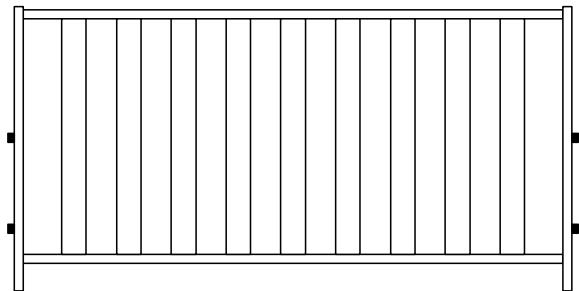

Back Deck

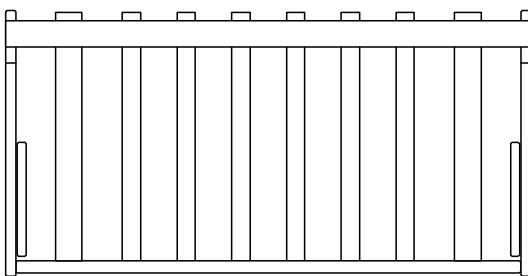

Ottoman Deck (with Legs)

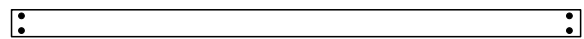

Rear Stretcher

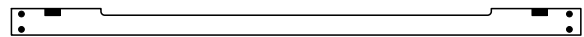

Front Stretcher (with Metal Strike Plates)

1C Hardware in this box.

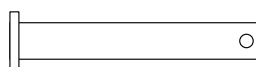

Clevis Pins
x 2 Pieces



Locking Pins
x 2 Pieces

i Instructions for the Arm assembly, are packed in the Arm box.

2A Prepare Arms for Assembly.

NOTE: The hardware for these steps is included with the Arms. Some Arms may not have these features, so just skip these steps.

Fasten Stretcher Brackets to Arm.

Fit Wooden Dowels.

- Insert the Stretcher Bracket Cleat into the hole provided.
- IMPORTANT:** Don't fully tighten Bracket until Stretchers are all in place for easy alignment.
- Each arm requires two brackets, front and back.

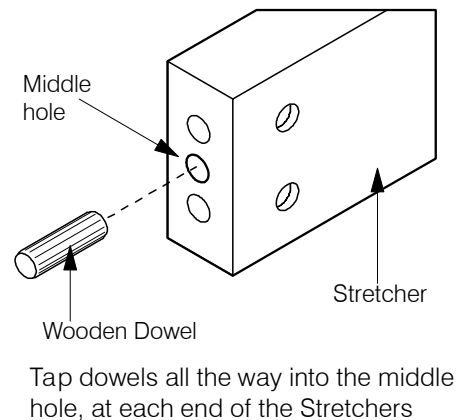
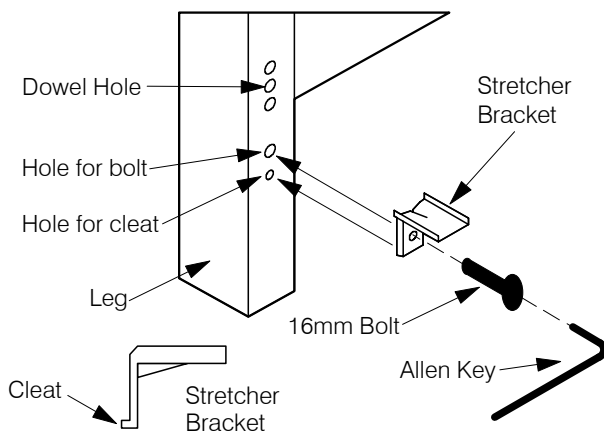

2B Attach Arms to Stretchers.

Your arm style may vary.

Using Bolts and Barrel Nuts provided with the Arms, attach the Arms LOOSELY to the Stretchers as shown.. It is important that these bolts are left loose!

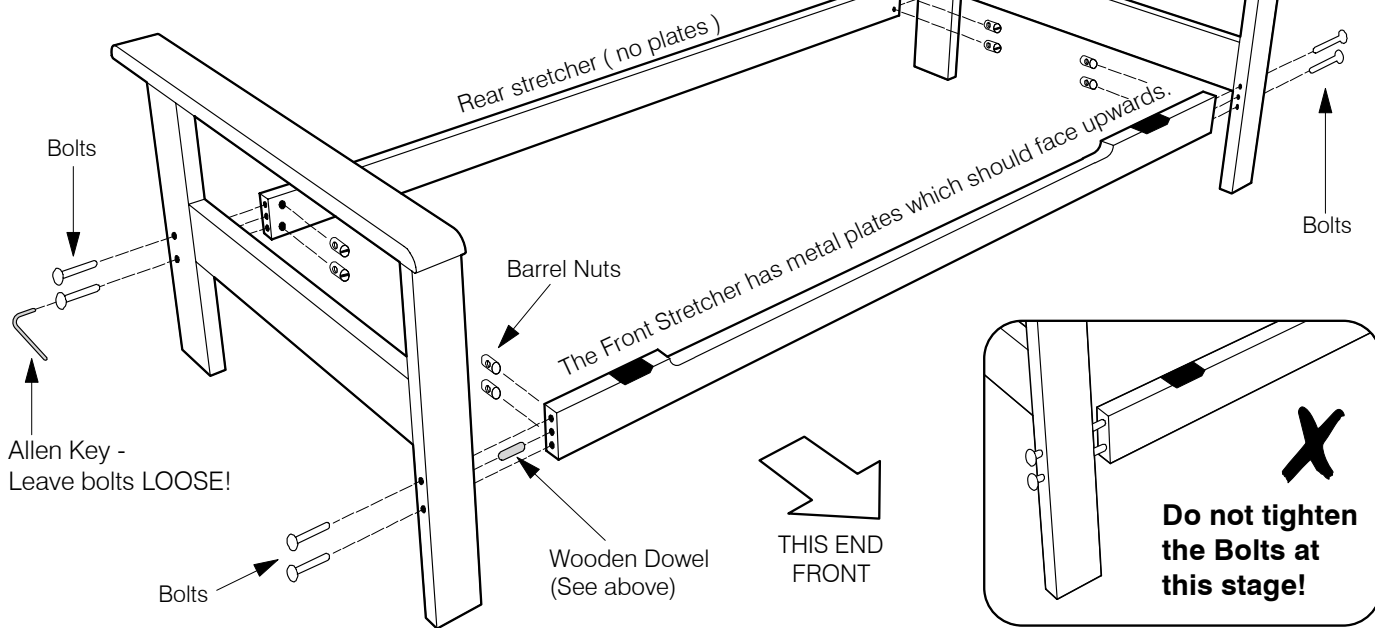

BOLT AND BARREL NUT ASSEMBLY SYSTEM

- ✓ Insert Barrel Nuts as shown using a screwdriver. This will help you position the Nut in line with the Bolt.
- ✓ Do not force the Bolt as you may strip the thread. Be sure the thread is properly started.

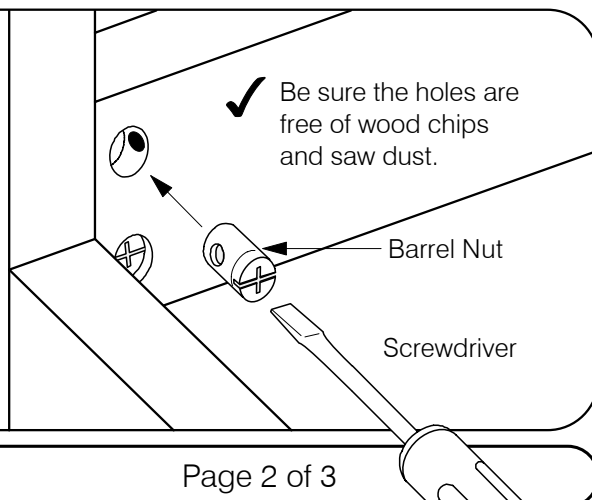
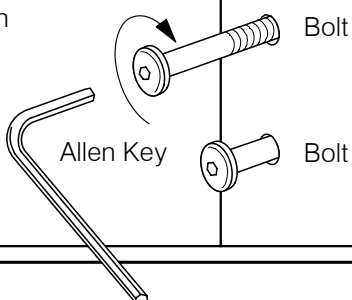

3A Fit Back Deck into Position.

A. Insert the Back Deck lying flat. Insert one end first, then gently lower the other end into position.

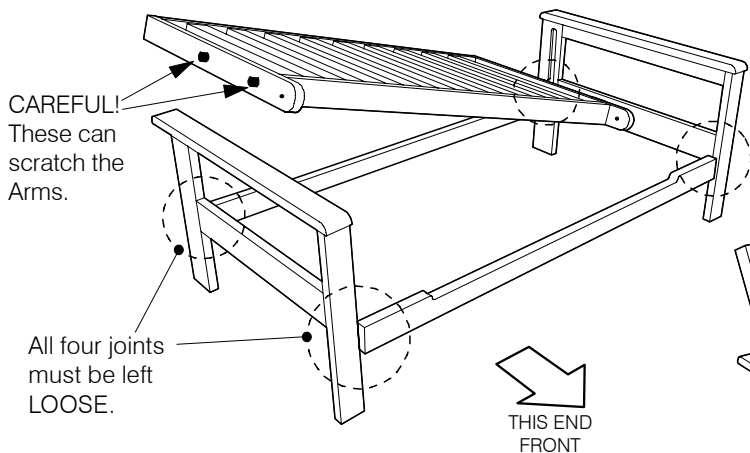

B. When you have the Back Deck fitted lying flat, tighten all the Bolts. From the back, lift the Back Deck to upright as illustrated.

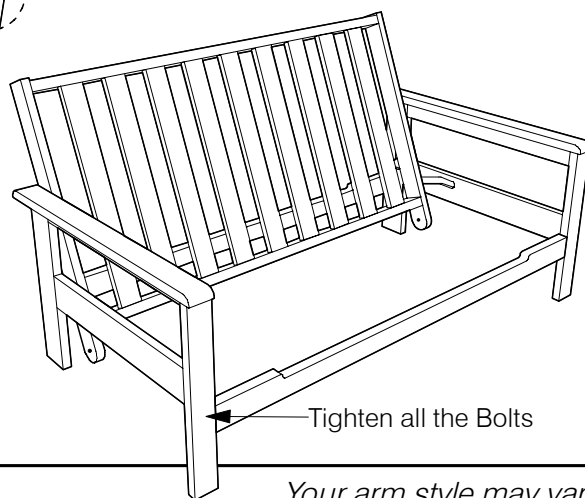

Your arm style may vary

- ✓ This step can be tricky - it is best done with two people
- ✓ Remember that the Bolts on the Arm should be LOOSE.
- ✗ Be careful not to scratch the Arms with the Plastic Runners when you lower the ends of the Back Deck.

3B Fit Seat Deck into Position.

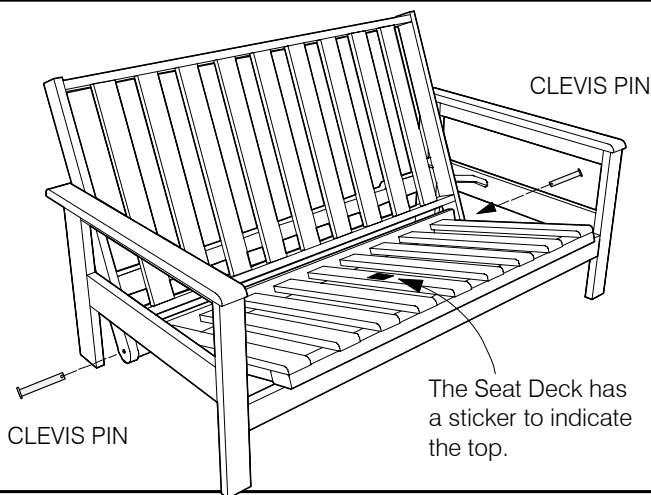

Fit the Seat deck between the Back Deck as shown. Use the Clevis Pins to connect the two decks. Secure with a Washer and Locking Pin.

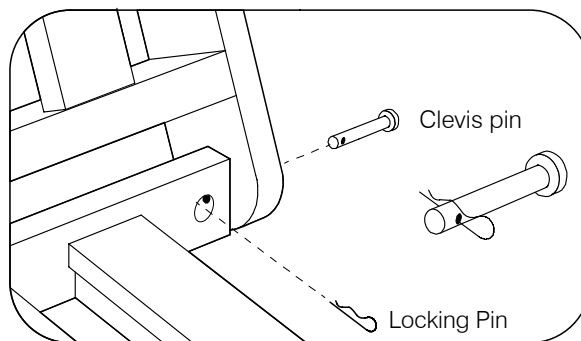

3C Hook the Ottoman Deck onto the Seat Deck.

Your arm style may vary

A. Extend the small legs on the Ottoman Deck.

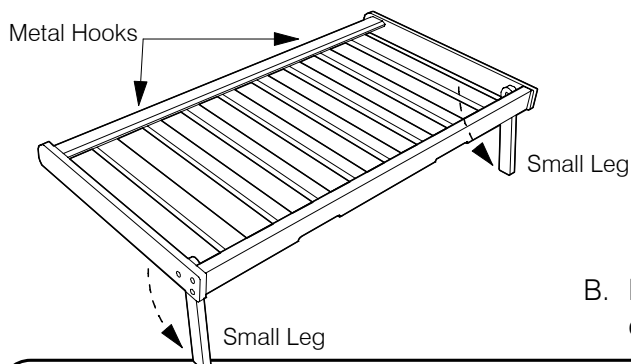

B. Hook the Ottoman Deck on to the Seat Deck

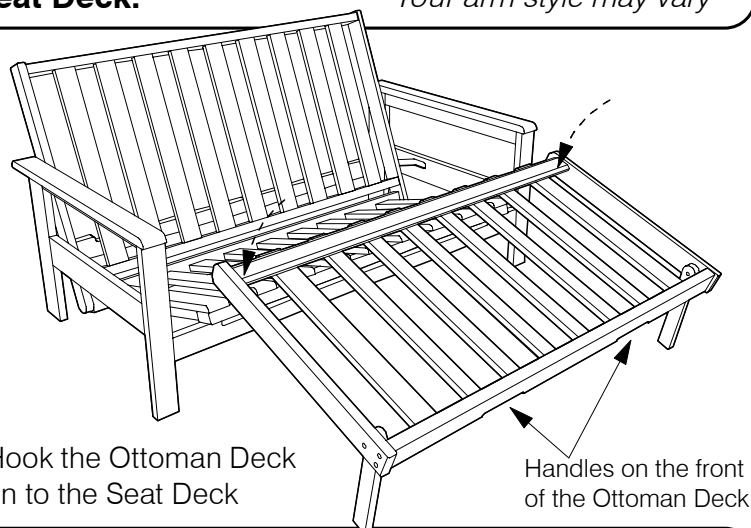

Operating Instructions

BIFOLD FUTON FRAME LOUNGER

Your Arm style may vary from that illustrated below.

N&D-OP1-1001

1 Important Note

- For your convenience and safety, we recommend that you remove the Mattress before adjusting the position of your Futon Frame.

2 Extending the Ottoman Deck in the Seating Position



The Sofa Position.

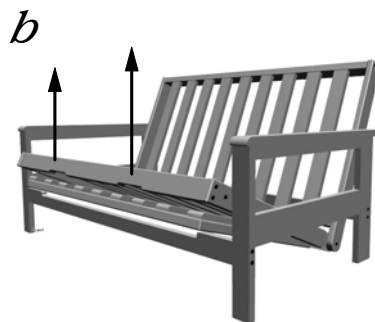

Lift up from the front, using both handles.

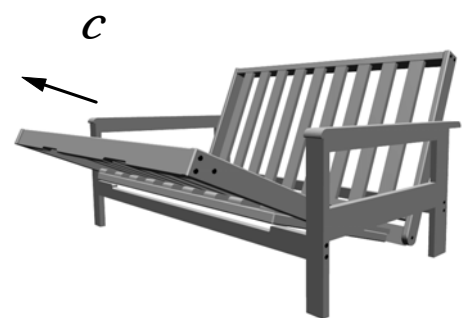

Gently Pull the Ottoman Deck out, all the way.



Lower the Ottoman Deck to the floor.



The Steamer Position.



Extend the Small Legs for the Lounger Position.



Fold away the Small Legs.



Lift up the Ottoman Deck with both Handles.

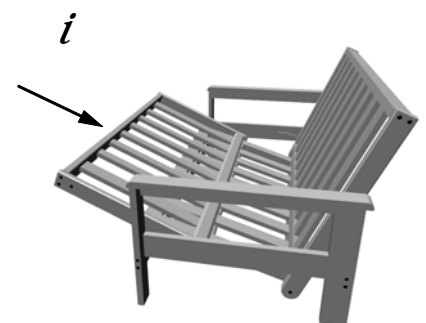

Gently slide back all the way, back to the Sofa Position.

3 Converting the Lounger to the Bed Position.



The Lounger Position - Remove that Mattress!

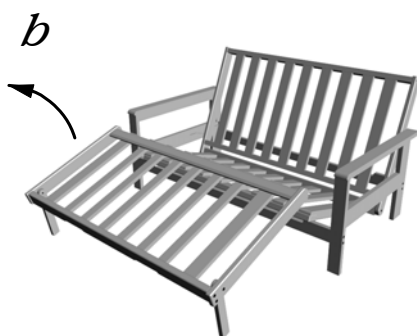

Unhook the Ottoman Deck.

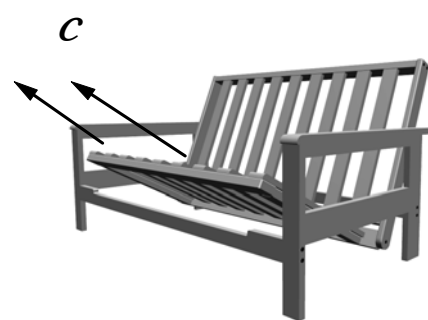

Pull up gently, letting the back drop down slowly.

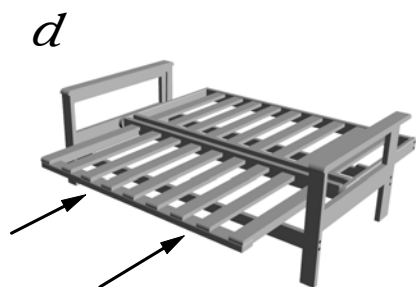

Important! Push to lock.



Carefully hook the Ottoman Deck onto the front Rail.



The Bed Position.

4 Converting back to the Lounger Position.



Remove the Ottoman Deck.

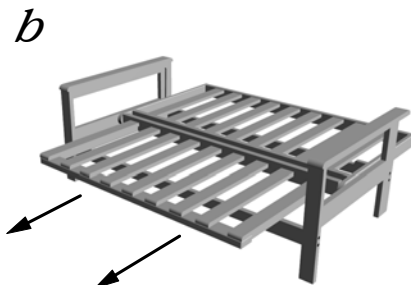

Don't Forget! Pull to unlock.

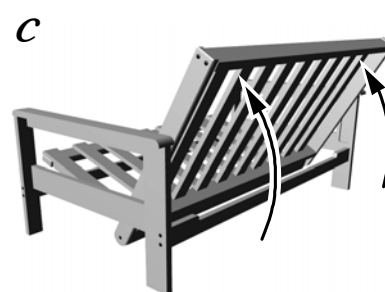

FROM THE BACK:
Lift up gently, up to the Reclined Sofa Position.

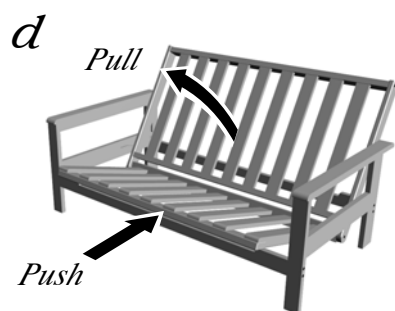

FROM THE FRONT:
Pull on the Back Deck,
and Push with your leg.

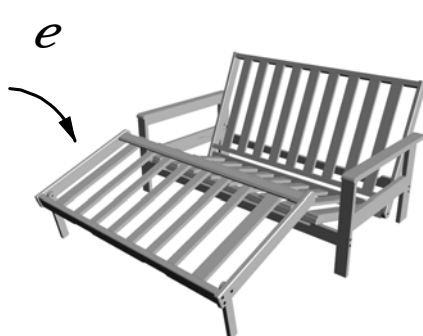

Carefully hook the Ottoman Deck onto the front Rail.



The Lounger Position.