

1 Packed in this box.

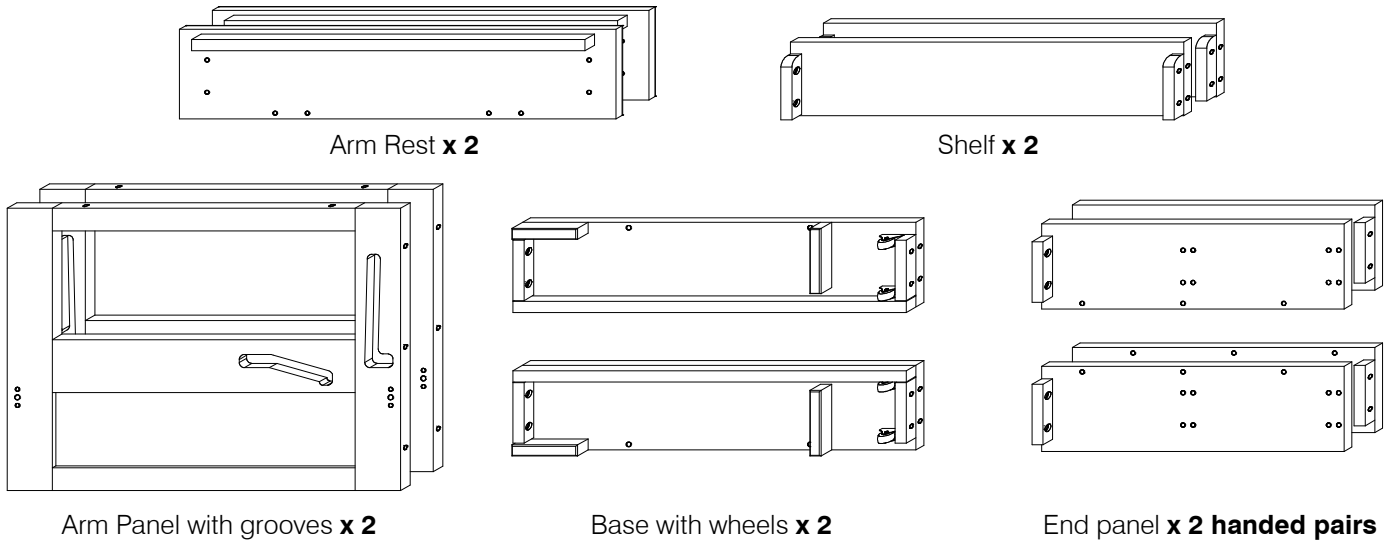

2 Hardware in this box.

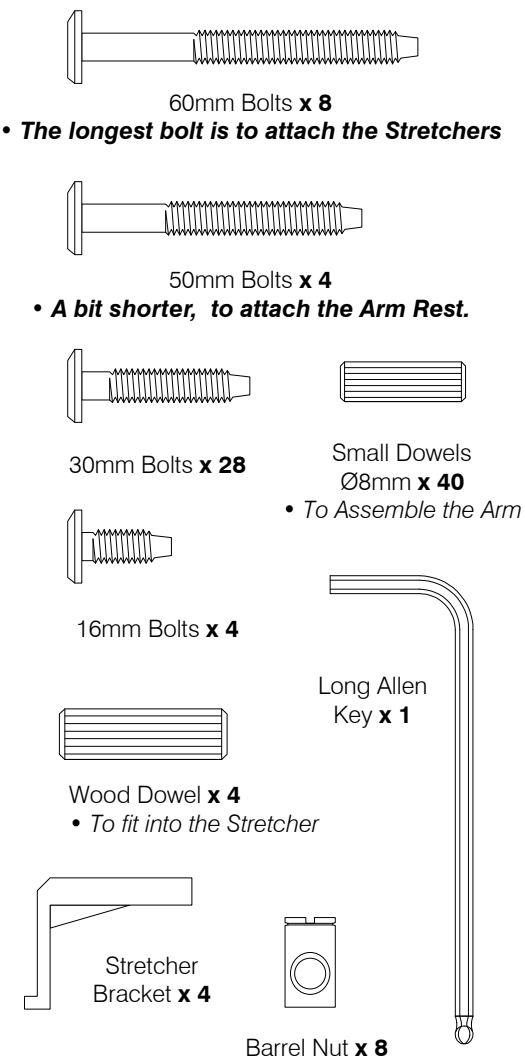

3 Fit the Base with wheels to the Arm Panel.

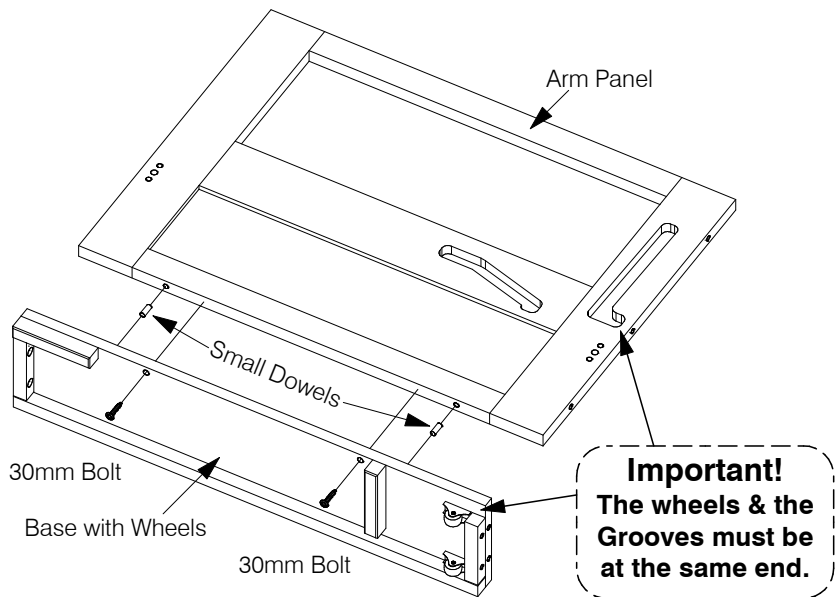

4 Fit the Shelf to the Arm Panel.

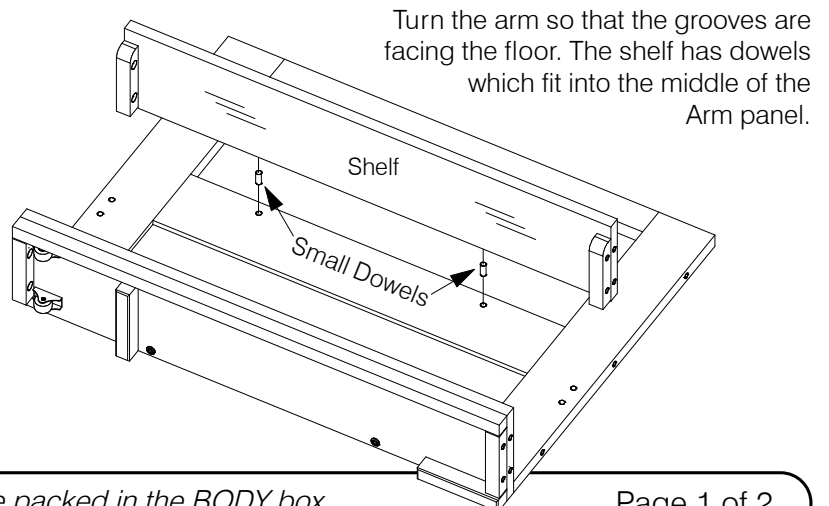

5 Fit a pair of End Panels to the Arms.

Each arm needs a handed pair of End panels.

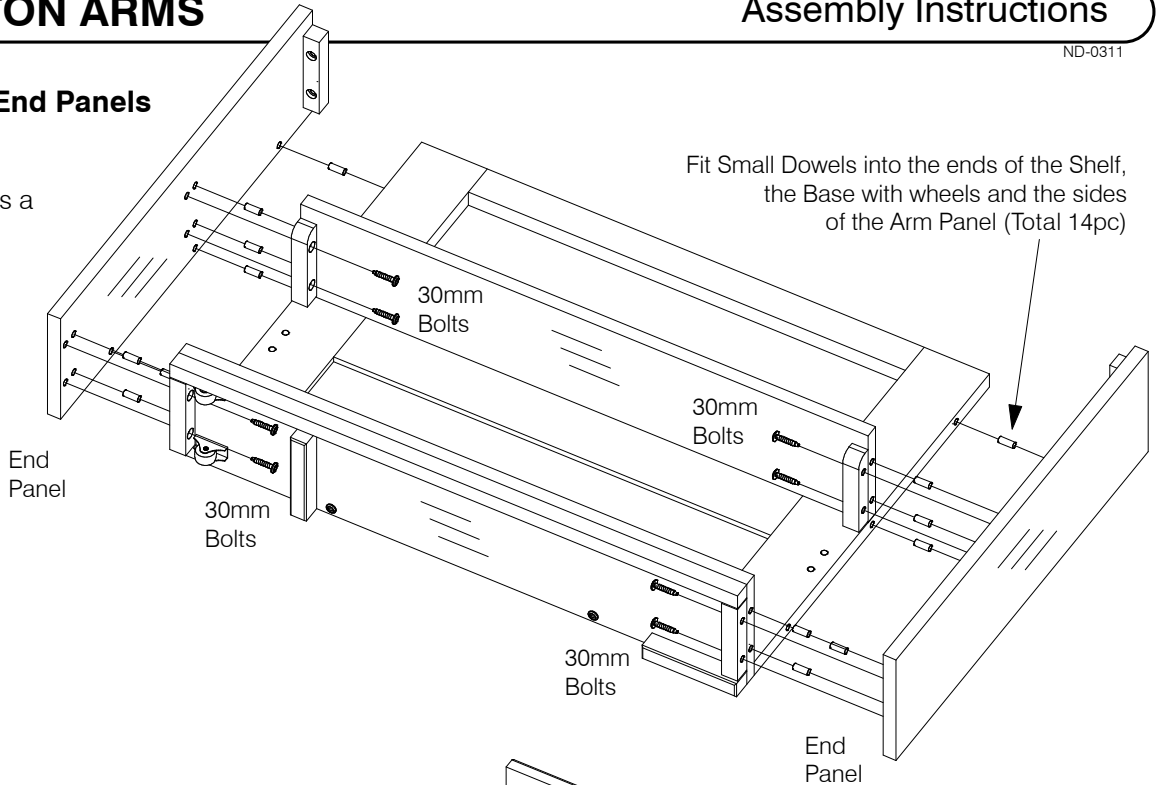

6 Fit the Arm Rest to the Arms.

Important!

Use the 50mm (2") Bolt



Not the longer 60mm Bolts

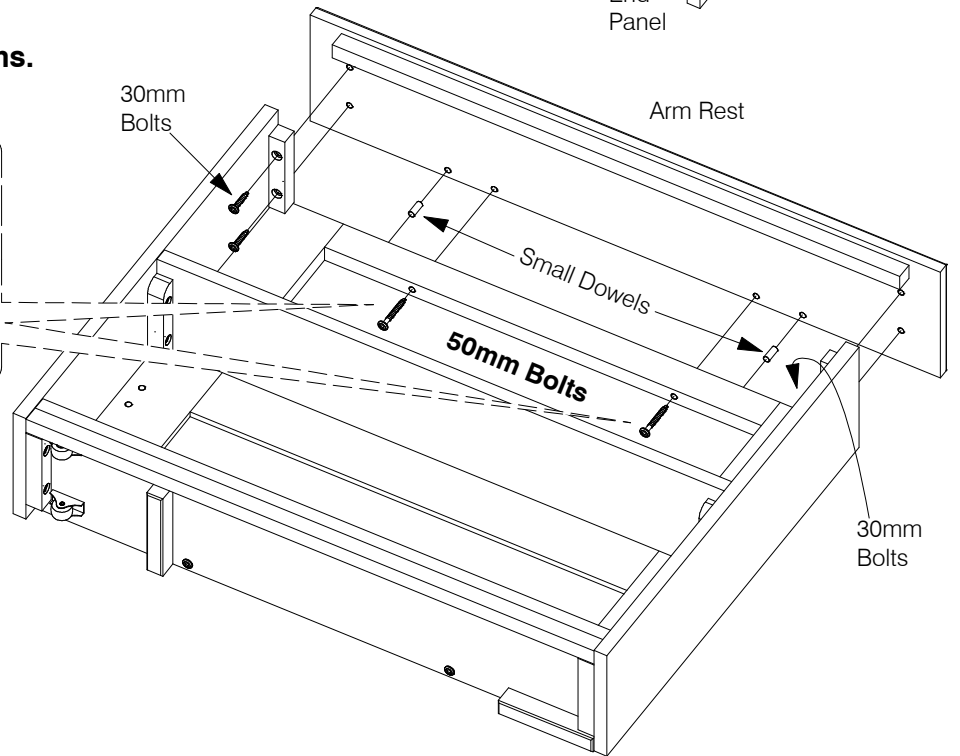

7 Fit the Stretcher Brackets to the inside of the completed Arms.

- Insert the Stretcher Bracket Cleat into the hole provided.
- IMPORTANT: Don't fully tighten Bracket until the Stretchers are all in place for easy alignment.
- Each arm requires two brackets, front and back.

